



WWW.FTX-RC.COM

RAMPAGE



1/10 SCALE SUPER-SIZE
4WD IC RACING BUGGY



SAFETY PRECAUTIONS

- This radio controlled racing car is not a toy!
- This high-performance R/C model is recommended for ages 14 and older.
- First-time builders should seek the advice of experienced modellers before commencing assembly.
- Take enough safety precautions prior to operating this model. You are responsible for this model's assembly and safe operation!

Part No:
FTX5510 (Blue)
FTX5511 (Orange)

INSTRUCTION MANUAL



WWW.CMLDISTRIBUTION.CO.UK



Required equipment for operation

1. Tools required for building and maintenance: (not included).

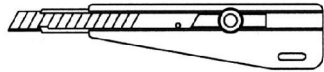

● Hobby knife

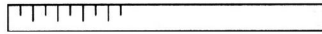

● Precision ruler or caliper

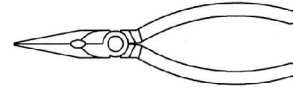

● Needle nose pliers

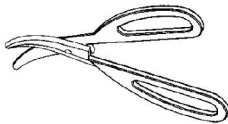

● Hobby scissors

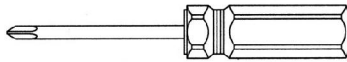

● Flat and Philips screwdriver

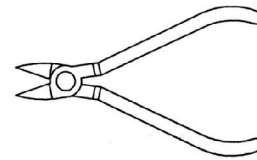

● Wire cutters

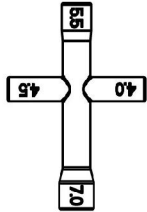

● Cross wrench

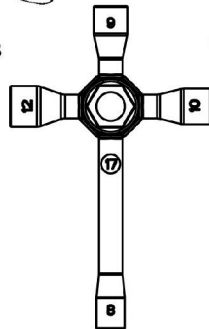

● Cross wrench



● CA glue & rubber cement

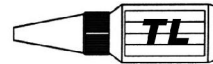

● Thread locking compound

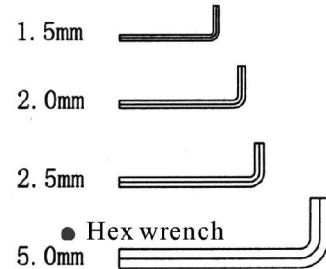

● Hex wrench

WARNING!

Do not use a power screw driver to install screws into nylon or plastic materials. The fast locking may heat up the screws being installed that may break the molded parts or strip the threads during installation.

2. Additional items needed for operation:



FTX5985
Transmitter



FTX5986
Receiver

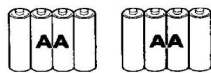

8pcs AA alkaline
batteries for
transmitter



FAST50
Glow igniter & its charger



FTX5987
3Kg Servo



VZ002
6.0V Ni-MH 2/3A1200mAh & its charger



FAST810



FAST22R
550cc Fuel Bottle

IMPORTANT!

Check all screws are tight before using the vehicle.
Use thread-lock on all screws that may work loose.



Please read the instruction carefully before start the assembly.

1. Please assemble and install this product without children. As the product includes small and sharp parts.
2. Do not run the truck in public street or highways. As it might cause serious accidents, personal injuries and property damage etc.
3. During the middle of racing and after operation, the engine and exhaust will become HOT. Therefore please do not touch them before cooling down.
4. Please make sure everyone is using different frequencies while racing the truck in the same area.

TRANSMITTER PREPARATION

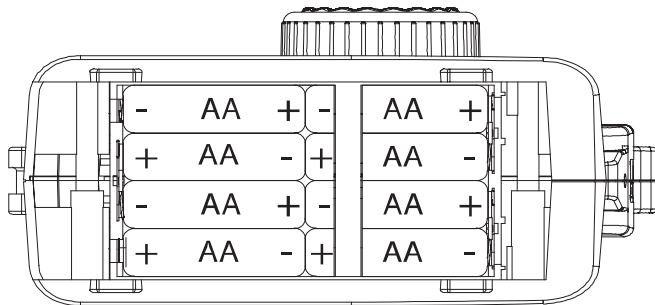

- Install eight "AA" batteries into transmitter, making sure the polarity is correct.
- Insert the antenna into the top of the transmitter and tighten.
- Turn the transmitter on and check the battery light.
- If all LED's light up, the batteries are acceptable. If only the red LED lights up, immediately replace the batteries.

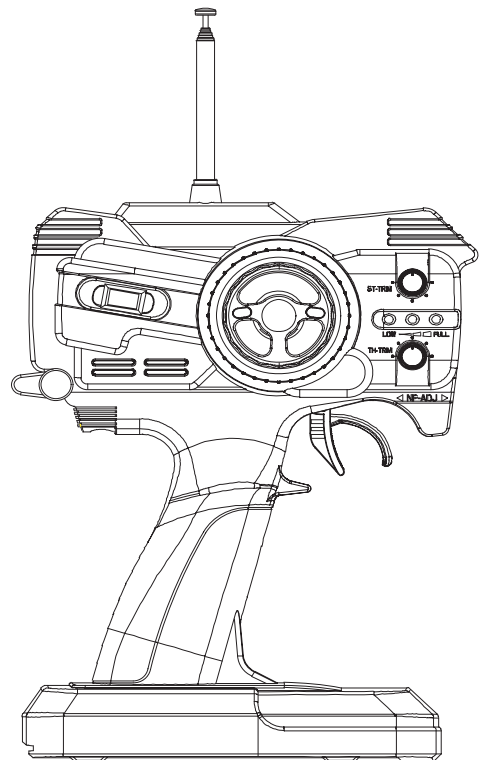



GLOSSARY OF TRANSMITTER

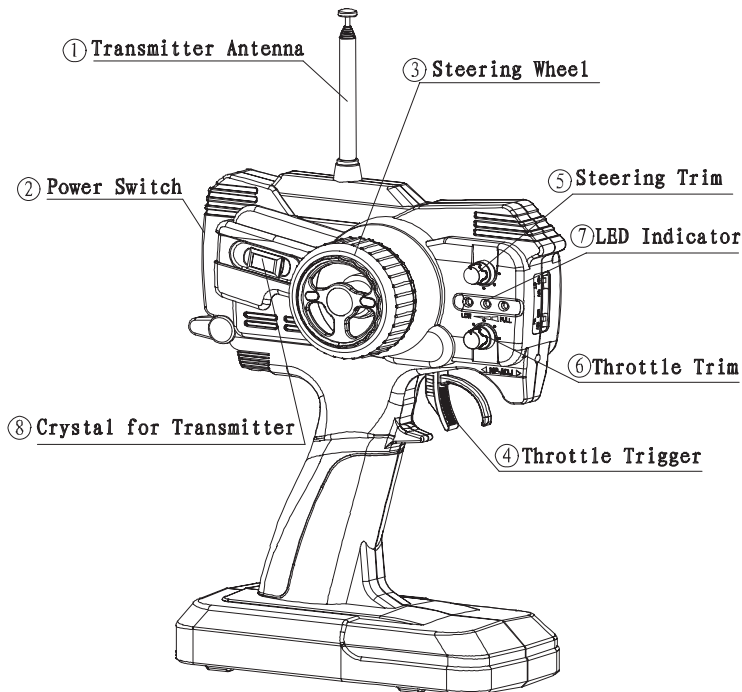

- ① The transmitter antenna is for transmit the radio waves.
- ② The power switch is for switching the power on/off.
- ③ The steering wheel is for controlling the direction of right/left.
- ④ The throttle trigger is for controlling the throttle and brake.
- ⑤ The steering trim is for adjusting the position of neutral.(right/left)
- ⑥ The throttle trim is for adjusting the carb in idle position.
- ⑦ The LED indicator is for showing the remaining amount of the battery.when turn on the power switch.
- ⑧ Crystal for transmitter is for changing the radio frequency by replacing the crystal.

BEFORE OPERATING

- Install the receiver antenna.
- Install the transmitter antenna.
- Loading the battery on the transmitter.
- Install the charged battery on the truck.

Please Note:
We recommend that you install a Failsafe Unit.

RC OPERATING PROCEDURES

1. Please pull out the transmitter antenna and then turn on the power switch first, before turning on the receiver.
2. Please raise the vehicle off the ground and check that the controls are responding correctly.
3. When the responses of the vehicle start to slow down please change or recharge the battery pack
4. When you finish the racing,please turn the receiver switch off first,and then the transmitter.
5. Please make sure the battery is disconnected and remove the battery after finishing racing.



ENGINE TUNING GUIDE

HIGH-SPEED NEEDLE

The "high-speed" needle is sticking up from the carburetor. This controls the fuel to air mixture of the carburetor. The needle is pre-set for break-in from the factory at 2-1/2 turns out from fully closed. Once the engine is broken-in, the high-speed needle would typically run from 2 to 2-1/2 turns out from closed, depending on the weather, humidity and altitude above sea level. To richen the mixture turn the needle counterclockwise. To lean it, turn the needle clockwise.

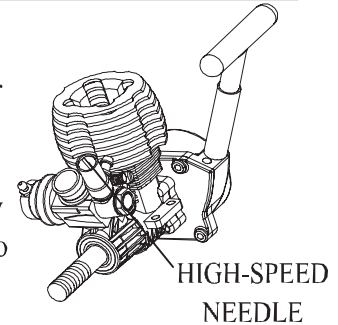

The Low-Speed Needle (For 18# engine)

The "low-speed" needle is the screw in the carb body opposite the throttle arm. It controls the fuel to air mixture at low throttle settings. There is a simple way of adjusting the low-speed needle correctly called the "pinch test." With the engine at idle, pinch the fuel line and listen to how the engine speeds up or slows down. If the engine increases its speed for about 2 or 3 seconds and then loses speed, the needle is set correctly. If the engine loses RPM quickly, it is set too lean and the low-speed needle needs to be opened (counterclockwise) to richen the mixture. Pinch again to check the mixture. If the engine takes longer than 4 seconds to slow down, lean (clockwise) the low-speed needle and then pinch again to check the mixture.

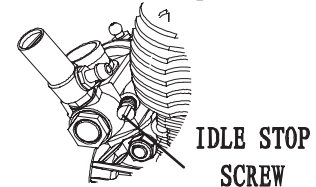

IDLE STOP SCREW

The "idle stop" screw is located on the backside of the carburetor. This increases or decreases the idle speed without changing the fuel mixture. The barrel should be approximately 1mm from fully closed.

IMPORTANT! To ensure long life and good performance from your engine, you MUST break-in the engine. The break-in period is critical for long life of the internal parts of the engine. This should be done over the first 5 tanks of fuel.

RUNNING THE ENGINE

STARTING THE ENGINE

IMPORTANT! Your radio system must ALWAYS be turned on and the transmitter antenna fully extended when running the engine!

1. Fill the fuel tank.
2. Prime the engine-while the engine is cool, place your finger over the tuned pipe's exhaust hole and pull the recoil gently several times. Do not over-prime! Stop when you see fuel in the fuel line at the carb. You may need to loosen the glow plug a little to help with this.
3. Install a "C" alkaline into the glow starter and attach the starter to the glow plug.
4. With the throttle at idle, start the engine by pulling the recoil using short, quick pulls. Do NOT pull the recoil starter's string to the end. You only need 10 to 12 inches of pull to start the engine with the throttle at idle.

Sometimes it is helpful to start the engine at around half throttle. When the engine starts, immediately return the throttle to idle. If this is not done the engine can over-rev and cause engine damage.



STOPPING THE ENGINE

Pinch the fuel line that runs to the carburetor. Pinching this line will restrict fuel flow and the engine will quit within a few seconds. Never place your finger over the exhaust to stop the engine. This could result in serious burns on your finger. It also causes fuel to back up in the engine, making it harder to start the next time you run your vehicle.

IMPORTANT! FIXING A FLOODED ENGINE

If the engine is difficult to turn over with the recoil starter, especially if it is brand new, loosen the glow plug a half turn before starting the engine. This allows some compression to escape, but the engine will still start. Make sure you tighten the glow plug after the engine starts. If the recoil starter is still difficult to pull, the engine is flooded—there is too much fuel inside the engine. Remove the glow plug, then turn the the buggy upside down and pull the recoil 5 or 6 times. This will clear the engine of fuel, and you will notice the recoil pulls easier. Replace the glow plug and repeat the starting procedure.

BREAK IN PROCEDURE

SOME THINGS TO REMEMBER DURING BREAK-IN

1. Run with the body off. This will keep the engine cooler.
2. Keep the air filter on at ALL time. Failure to do so will result in dirt entering the engine and instant damage.
3. Run on a smooth, hard surface. An empty parking lot is Perfect.
4. Use the same fuel that you will use for normal running.
5. Resist the urge to accelerate and decelerate quickly.
6. Break-in puts stress on the glow plug so it is adviseable to have at least one spare to hand.
7. DO NOT overheat the engine. You can check the head temperature by using a temperature gauge.

TANK 1

Your first tank of fuel should be running the vehicle at a very rich needle valve setting. This allows the fuel to carry as much oil as possible into the engine to properly lubricate the internal parts during the break-in.

1. Open the high speed needle valve 4-1/2 turns from fully closed (counterclockwise).
When closing the high-speed needle, close until you feel some resistance.
DO NOT overtighten or you will damage the engine.
2. Fill the fuel tank and start the engine.
3. Run the buggy on a smooth surface with the body off.
4. Run back and forth at medium speeds, slowly accelerating and decelerating the buggy.
5. Run the buggy until the tank is almost out of fuel. Do not allow the tank to run out of fuel during break-in. This leans out the engine and can cause overheating.
6. Stop the engine and allow it to cool. This normally takes around 10-15 minutes.

NOTE: if your engine does not stay running consistently, increase the idle speed by turning the idle stop screw clockwise.

TANK 2

Lean the high-speed needle 1/12 turn from "tank 1" setting. Run the buggy for the complete tank and then let cool.



TANK 3

Lean the high-speed needle another 1/12 turn from "tank 2" setting. Run the buggy for the complete tank and then let cool.

TANK 4

Lean the high-speed needle another 1/12 turn from "tank 3" setting. Run the buggy for the complete tank and then let cool. You should notice the engine running much better at this point.

TANK 5

Lean the high-speed needle another 1/12 turn from "tank 4" setting. Run the buggy for the complete tank and then let cool. The engine is now ready to be performed tuned. Important! At this point, the engine will likely be running at a faster idle than needed (This is typical after break-in). Adjust the idle stop screw to lower the idle speed so that the wheels do not, or just barely, rotate when you lift the buggy off the ground.

TUNING TIPS

After break-in, run the vehicle where you plan to do most of your driving (grass, street, track, etc). Tune the high speed needle so the engine makes good power without overheating. Using a temperature gauge, tune the engine so that it will consistently stay under 270 F (132 C). Keep in mind. RC engines usually take a minute or two to warm up. It is common not to reach full power right away. Never tune a cold engine!

ENGINE CARE

Never store your car with fuel in the tank. We recommend that after the final run of the day, you empty the fuel tank and then run the engine at idle until all the fuel is out of the fuel lines and engine. Remove of air filter and glow plug. Then place two drops of the After Run Engine Oil in the carburetor and two into the cylinder to help prevent corrosion. Pull the re-coil a few times to circulate the oil.

10 WAYS TO ENSURE LONG LIFE FROM YOUR ENGINE

1. Keep your engine and air filter clean. Dirt will act as insulation on an engine. it will not be able to shed heat as easily. Clean and re-oil the element often.
2. Do not over-lean your engine.
3. Do not run your engine with little or no load. Don't throttle up the engine to full throttle when the wheels are not in contact with the ground.
4. Do not overheat the engine.
5. Do not use a fuel with a low oil content. Make sure you use a model car fuel from a reputable manufacturer, such as Byron Fuel.
6. Avoid using old fuels in the engine.
7. Do not use a fuel with a nitromethane (often called nitro) content over 20%.
8. Do not scratch the piston or cylinder sleeve. Avoid jamming something into the exhaust port when removing or re-installing the clutch or flywheel. Use a special tool called a Flywheel Wrench to keep the crankshaft from moving.
9. Do not use silicone sealer on the engine joints. Silicone sealer contains acetic acid, which is corrosive if it gets inside your engine.
10. Do not allow any water to get inside the engine. This sounds easy, but temperature changes can cause condensation inside the engine. This is a good reason to use an after-run oil. Store your engine inside the house, not in a garage or shed where there will be temperature extremes.

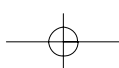
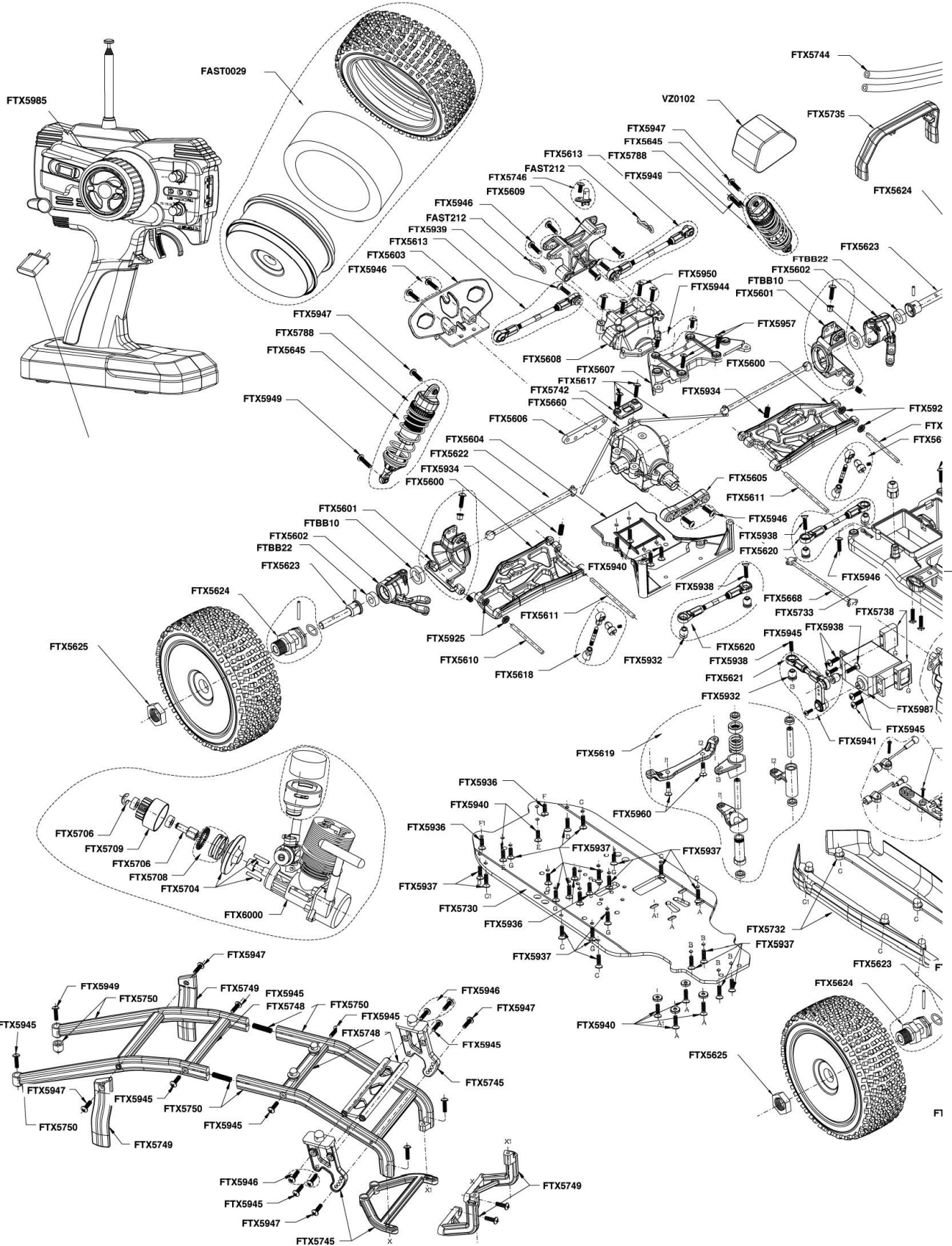
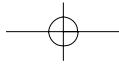

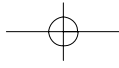

Parts Listing

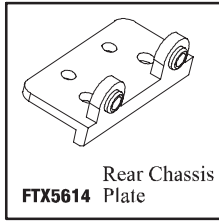

FTX5614 Rear Chassis Plate

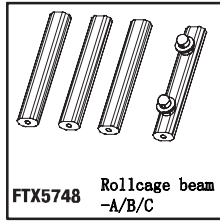

FTX5748 Rollcage beam -A/B/C

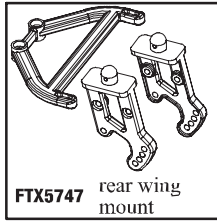

FTX5747 rear wing mount

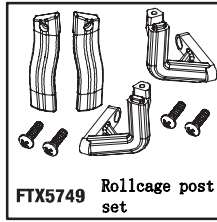

FTX5749 Rollcage post set

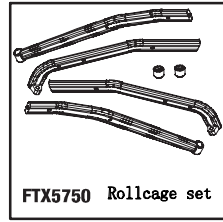

FTX5750 Rollcage set

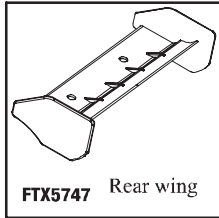

FTX5747 Rear wing

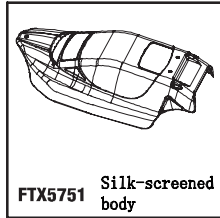

FTX5751 Silk-screened body

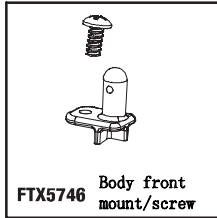

FTX5746 Body front mount/screw

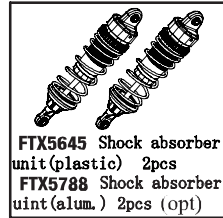

FTX5645 Shock absorber unit(plastic) 2pcs
FTX5788 Shock absorber unit(alum.) 2pcs (opt)

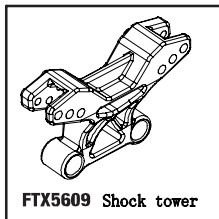

FTX5609 Shock tower

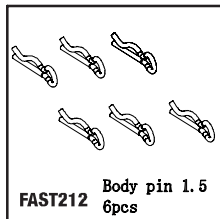

FAST212 Body pin 1.5 6pcs

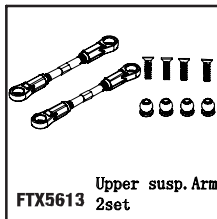

FTX5613 Upper susp. Arm 2set

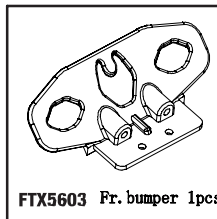

FTX5603 Fr. bumper 1pcs

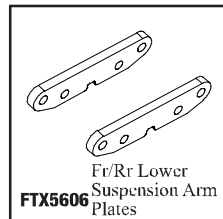

FTX5606 Fr/Rr Lower Suspension Arm Plates

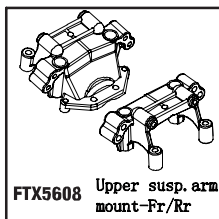

FTX5608 Upper susp. arm mount-Fr/Rr

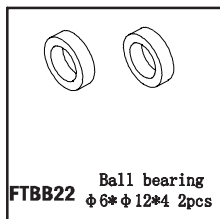

FTBB22 Ball bearing $\phi 6 * \phi 12 * 4$ 2pcs

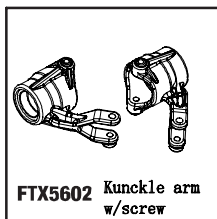

FTX5602 Kunckle arm w/screw

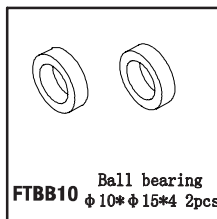

FTBB10 Ball bearing $\phi 10 * \phi 15 * 4$ 2pcs

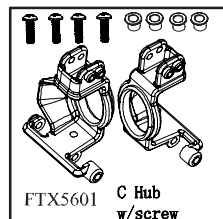

FTX5601 C Hub w/screw

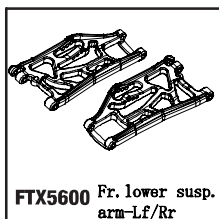

FTX5600 Fr. lower susp. arm-Lf/Rr

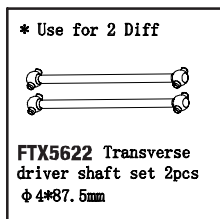

* Use for 2 Diff
FTX5622 Transverse driver shaft set 2pcs $\phi 4 * 87.5 \text{mm}$

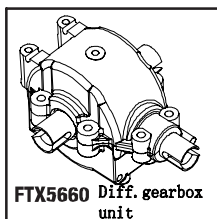

FTX5660 Diff. gearbox unit

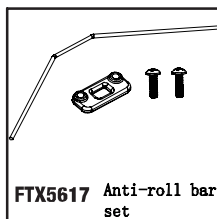

FTX5617 Anti-roll bar set

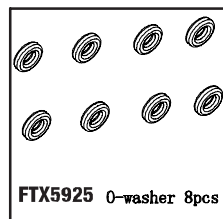

FTX5925 O-washer 8pcs

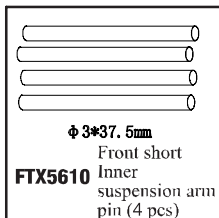

$\phi 3 * 37.5 \text{mm}$
FTX5610 Front short Inner suspension arm pin (4 pcs)

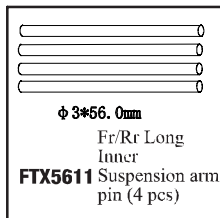

$\phi 3 * 56.0 \text{mm}$
FTX5611 Fr/Rr Long Inner Suspension arm pin (4 pcs)

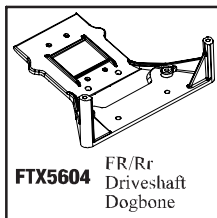

FTX5604 FR/Rr Driveshaft Dogbone

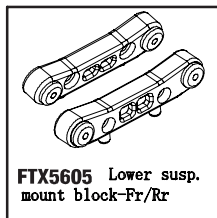

FTX5605 Lower susp. mount block-Fr/Rr

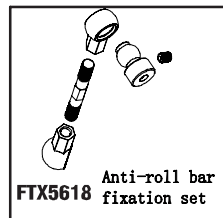

FTX5618 Anti-roll bar fixation set



FTX5620 Steeringlinkage set 2set

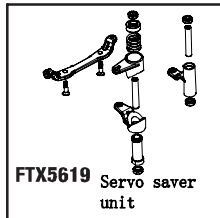

FTX5619 Servo saver unit

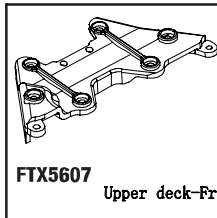

FTX5607 Upper deck-Fr

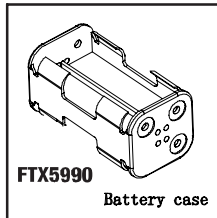

FTX5990 Battery case

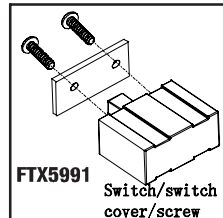

FTX5991 Switch/switch cover/screw

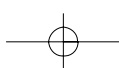

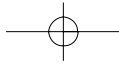

Parts Listing

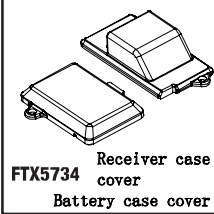

FTX5734 Receiver case cover
Battery case cover

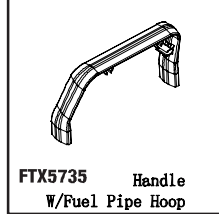

FTX5735 Handle
w/Fuel Pipe Hoop

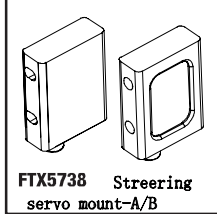

FTX5738 Steering servo mount-A/B

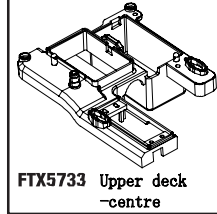

FTX5733 Upper deck -centre

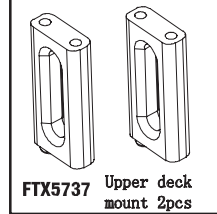

FTX5737 Upper deck mount 2pcs

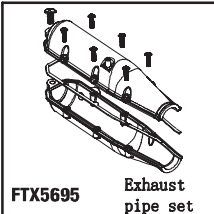

FTX5695 Exhaust pipe set

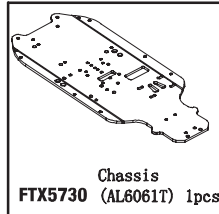

FTX5730 Chassis (AL6061T) 1pcs

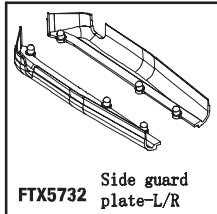

FTX5732 Side guard plate-L/R

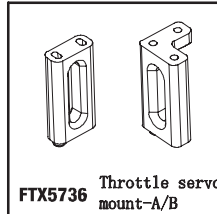

FTX5736 Throttle servo mount-A/B

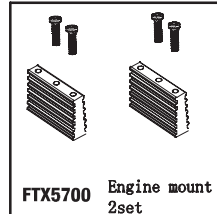

FTX5700 Engine mount 2set

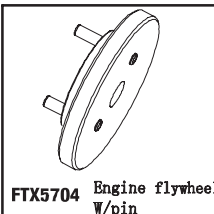

FTX5704 Engine flywheel w/pin

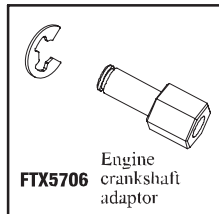

FTX5706 Engine crankshaft adaptor

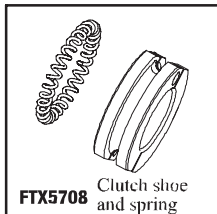

FTX5708 Clutch shoe and spring

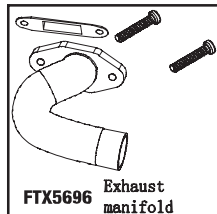

FTX5696 Exhaust manifold

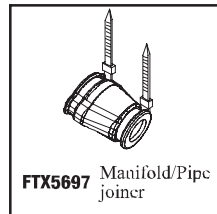

FTX5697 Manifold/Pipe joiner

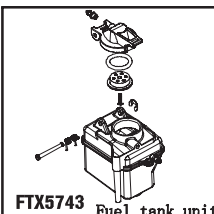

FTX5743 Fuel tank unit

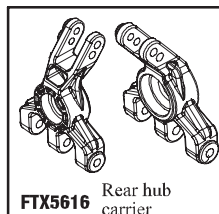

FTX5616 Rear hub carrier

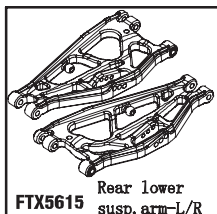

FTX5615 Rear lower susp. arm-L/R

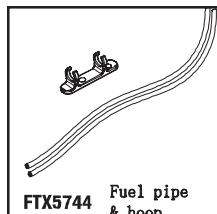

FTX5744 Fuel pipe & hoop

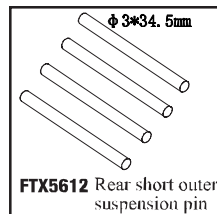

FTX5612 Rear short outer suspension pin

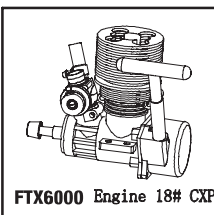

FTX6000 Engine 18# CXP

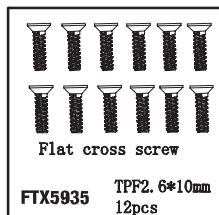

Flat cross screw
FTX5935 TPF2. 6*10mm 12pcs

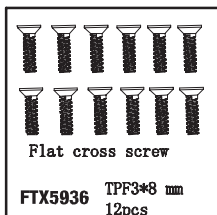

Flat cross screw
FTX5936 TPF3*8 mm 12pcs

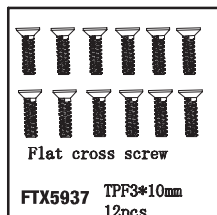

Flat cross screw
FTX5937 TPF3*10mm 12pcs

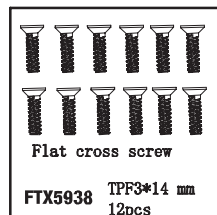

Flat cross screw
FTX5938 TPF3*14 mm 12pcs

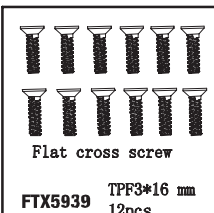

Flat cross screw
FTX5939 TPF3*16 mm 12pcs

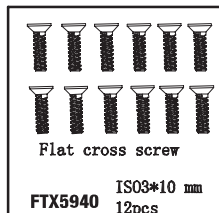

Flat cross screw
FTX5940 IS03*10 mm 12pcs

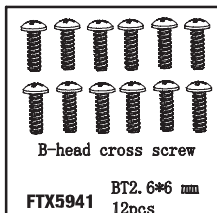

B-head cross screw
FTX5941 BT2. 6*6 mm 12pcs

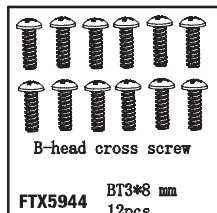

B-head cross screw
FTX5944 BT3*8 mm 12pcs

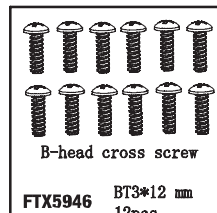

B-head cross screw
FTX5946 BT3*12 mm 12pcs

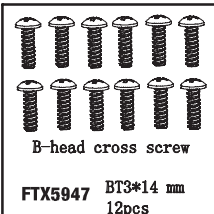

B-head cross screw
FTX5947 BT3*14 mm 12pcs

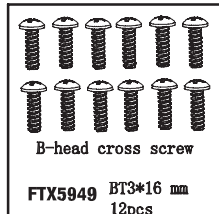

B-head cross screw
FTX5949 BT3*16 mm 12pcs

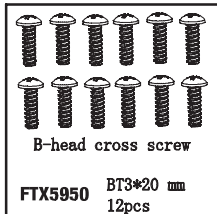

B-head cross screw
FTX5950 BT3*20 mm 12pcs

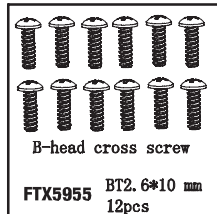

B-head cross screw
FTX5955 BT2. 6*10 mm 12pcs

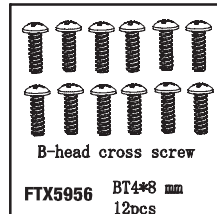

B-head cross screw
FTX5956 BT4*8 mm 12pcs

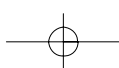

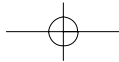

Parts Listing

one set

FT270025 Crystal RED
FT270095 Crystal ORANGE
FT270145 Crystal YELLOW
FT270195 Crystal GREEN
FT270255 Crystal BLUE

FTX5710 Air filter w/insert

B-head cross screw
FTX5961 BT3*10 mm 12pcs

AM

FTX5985
 Transmitter complete

AM

FTX5986
 Receiver 1pcs

FTX5987 3kg servo

FAST0029

 Tire unit 2pcs

FTX625 Nut M12

FTX5624 Rim hub pin (2*16)/0-ling

FTX5623 Axle

Option Parts

Aluminium AL6061

FTX5775 Wheel Hex Set

Aluminium AL6061

FTX5776 C HCB C HCB Pin

Aluminium AL6061

FTX5777 Knuckle Arm set

Aluminium AL6061

FTX5778 Rear Hub set

Aluminium AL6061

FTX5779 Shock stay mount

Aluminium AL6061

FTX5780 Front suspension mount

Aluminium AL6061

FTX5781 Rear suspension mount

Stainless steel

FTX5782 Steel brake disk

Stainless steel

FTX5783 Special brake pads

Aluminium AL6061

FTX5784 Brake post

Aluminium AL6061

FTX5785 Steering bar

Aluminium AL6061

FTX5786 One pcs engine mount

Stainless steel AL6061

FTX5788 Shock absorber unit (alum.)

Aluminium

FTX5789 Metal pipe

FTX5945 3x10BH Screw

FTX5621 Servo Horn

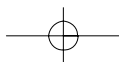

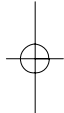
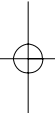
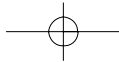

DISTRIBUTORS OF QUALITY MODEL & HOBBY PRODUCTS

Saxon House, Saxon Business Park, Hanbury Road, Bromsgrove, Worcestershire. B60 4AD. England

Tel: +44 (0) 1527 575349

Fax: + 44 (0) 1527 570536

E-mail: info@cmldistribution.co.uk

Web site: www.cmldistribution.co.uk

